

# Louvlux



## COMPANY & PRODUCT OVERVIEW 2024



Koolshade® Passive, Dynamic & Movable.  
The Ultimate Solar Shading Fabric

# Louvlux

## COMPANY

- | 04 | About Us
- | 06 | KoolShade® Metal Fabric for Solar Shading
- | 08 | Applications

## PRODUCT

- | 10 | KoolShade® Construction. Weaving & Fabrication
- | 12 | Installation Options
- | 18 | Sustainability

## INFORMATION

- | 20 | Project Examples
  - *Hazendal Wine Estate*
  - *Monterrey Airport*
  - *Huu-ay-aht First Nations*
- | 28 | Colours & Finishes
- | 30 | Certification & Accreditation

KoolShade® metal louvred fabric is unbeatable at stopping solar heat gain in buildings. As a passive, dynamic or movable system, it makes hot places cool, reduces the need for air-con by nearly 70% and makes usually too hot venues usable all year round.

## *COOL BUILDINGS*



## *SUSTAINABLE HOMES*

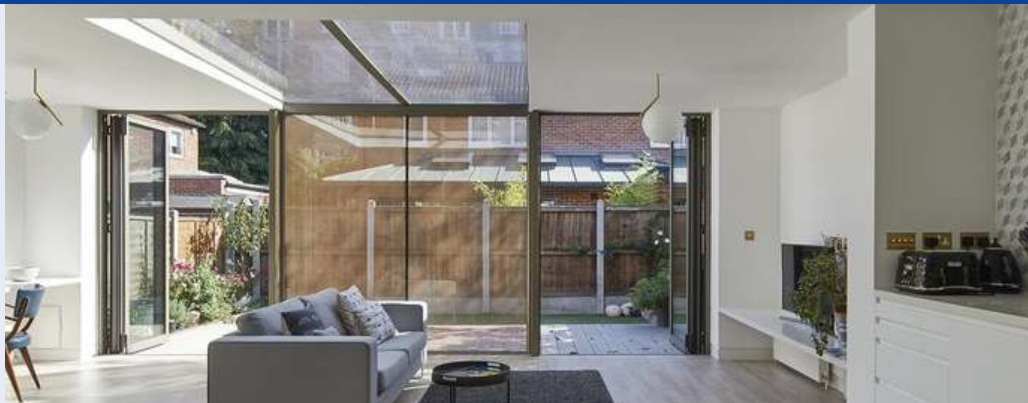

## *USABLE VENUES*



# 4

About Us

Smartlouvre Technology is the sole, global manufacturer of Koolshade® metal fabric, the ultimate in shading from solar heat.

The fabric was invented by two senior research members of Dow Chemical and first manufactured in conjunction with the Borg-Warner Corporation.

Fabric screens were being mass produced for commercial building application across the US, and later throughout the globe by a distributor network.

The factory was destroyed in 1989 by a hurricane and although re-built, production was affected by months of power outages and supply chain problems, and never recovered.

The original weaving machines which were gathering dust, were shipped over to the UK. SLTechnology has taken over the manufacturing and brought it into the 21st century, by computerising the machines.

Whilst continuing to invest in manufacturing Smartlouvre focused on providing unique apprenticeships and training, supporting our young engineers of the future.

The production volumes have increased and new weaving machines are producing fabric that is being used on the most sustainable buildings in the world.

As our climate changes, there is a fast growing need for PASSIVE ways to reduce temperatures in buildings.

#### **Koolshade® achieves this.**

From a VERY smart idea, realised decades ago, to one the most effective ways to shade our planet from a modern challenge.

We serve diverse fields of Solar Shading, Daylighting, Thermal, Visual and Environmental Comfort, Fire Protection, Privacy and Security, Night Sky Pollution, Anti-Glare Lighting, Light Trespass, and even Insect Screening and Bird-Strike Protection.

**In short, there is no other product as versatile, or effective, as Koolshade®.**

## **WE ARE A WEAVER OF A TOTALLY UNIQUE METAL FABRIC USED FOR SOLAR HEAT CONTROL**

#### **Our vision.**

Our core business lies in the manufacture of a totally unique, tried and tested high-performance heat blocking and glare reduction shading system that creates better working and living environments for people in commercial, public, and residential buildings, whilst dramatically reducing air-conditioning running and equipment costs.

We, at Smartlouvre, are committed to providing sustainable and innovative solutions that reduce energy consumption, protect the well-being of occupants and maintain superior comfort levels.

Koolshade® provides 100% shade and 100% heat block, saving over 68%\* of air conditioning costs. It also allows perfect vision and outperforms all other external solar shading systems.

#### **The ideal Passive House shading material.**

**LOUVLUX**  
Expert Shading Solutions

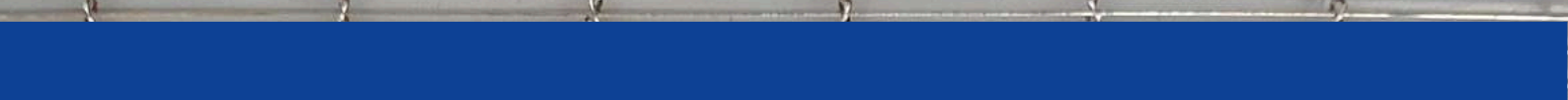



**Solar shading is a method by which solar radiation in the form of heat and light can be mitigated in a building.** While natural heat and light are essential in most buildings and modern architecture uses it more and more there are occasions when the levels are too high. This leads to high temperatures and too much light.

Solar shading is a general term for a range of methods used to reduce the amount of solar gain. Our Koolshade® fabric fits easily on the outside of windows thus reducing the amount of heat gain and direct sunlight whilst still allowing a clear view through the window.

## SHADING AGAINST INCREASINGLY HOT SUMMERS AROUND THE GLOBE

The micro fine louvres protect the building and windows from debris and dust. They are simply fixed to the building and do not need to be removed for maintenance. Project examples exist that are directly fixed and have been in place for over 60 years, across the globe.

**Cleaning of the glass can be performed without removal of the screen through simple pressure washing when required.**

Some buildings simply prefer the option of moveable/removeable screens and for these, we offer engineered solutions.

Screens can be configured to discretely replicate or complement the style and colour of the building facade.

As a solar shading solution it offers many benefits and doesn't suffer from mechanical problems or user error because of its passive nature.

Fixings depend on the facade or window frame materials. The preferred option is to use mechanical fixings but due to the lightweight nature of the screens, adhesive solutions such as **3M VHB Dual Lock** or Foam Tape can also be used.

**We are proud to have sensitively restored heritage and listed buildings around the world.**

KoolShade® solar screens are the result of decades of extensive and exhaustive international research and development. It is probably the most efficient modern method of solar shading in the world.

The fabric was invented in the late 1930s by John J. Grebe who was then Director of Nuclear Research at The Dow Chemical Company.

The totally unique weaving machines were developed in Co-operation with BorgWarner and the Koolshade product was born.

It **does not** allow the hot solar radiation through, it gets deflected by the angled micro-louvres.

## HOW DOES KOOLSHADE® WORK?



## WHEN THE SUN IS AT 45°, TOTAL SHADING IS PROVIDED

Even with temperatures well **in excess of 40°+** no direct solar heat gain will reach the inside of the building. Zero heat gain, reduced glare but with perfect vision out.

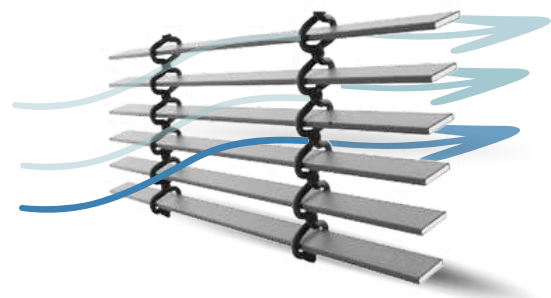
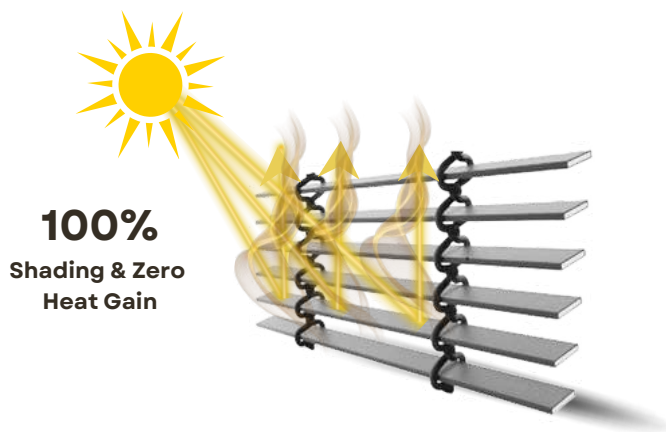

## LIGHT & AIR PASS THROUGH KEEPING ROOMS WELL LIT & COMFORTABLY COOL.

**Fraunhofer ISE** states that KoolShade® fabric is an angleselective product, therefore angle-dependent transmittance and reflectance values have been tested at positive and negative angles of incidence.



The defined standards of EN14501 specify reporting results only at normal incidence (0°) and thus do not adequately indicate true performance at other, highly relevant angles of incidence.

Angular Dependent: meaning that the performance varies with the position of the solar altitude.

8

Applications

**We are a UK company providing high-quality solar shading systems for all commercial and residential buildings.** Our unique material is a highly efficient and effective part of solar shading architecture.

We make a totally unique and unbeatable mesh that offers efficient solar protection by keeping the insides of office buildings and public spaces significantly cooler and reducing the need for excessive air conditioning.

**Koolshade® invisibly neutralises solar heat gain and glare before they even reach the window.**

Koolshade® uniquely works non-stop providing dynamic g-value (heat blocking) performance to continually dissipate the sun's heat and energy into the atmosphere but not blocking vision out, natural daylight or natural ventilation; solar shading using our products is efficient and effective.

Our unique material is the perfect solar shading device, it can be installed easily, has excellent environmental credentials and offers a cost effective solution to solar gain.

**All glazing needs solar protection.** Working differently from traditional external, internal blinds and other solar shading devices, which reflect, distort, and restrict vision and light, Koolshade® invisibly neutralises solar heat gain and glare before they even reach the window. KoolShade Koolshade™ works non-stop to give you solar control, dissipating the sun's heat and energy into the atmosphere whilst allowing full vision out, and daylight and natural ventilation in. KoolShade Koolshade® solar shading systems are efficient, effective, and maintenance free with a zero-total cost of ownership.

## KOOLSHADE® WAS INVENTED TO STOP THE SUN'S HEAT BEFORE IT REACHES THE GLAZING

Windows exposed to the sun allow short wave radiation to flow through where it converts to long wave radiation which is then trapped inside allowing temperatures to exceed 38°C. Koolshade® solar shading louvre works totally differently from traditional external and internal solar shading blinds by simply and invisibly neutralising solar heat gain and glare.

It does this **before they even reach the window**, like a heat sponge soaking up the heat and energy and discharging it into the atmosphere like a chimney.

The standard alternatives like sunshades for buildings, mechanical solar shading louvres and solar shading blinds all have major flaws be it from potential user error, cost or efficacy; Koolshade® does not.

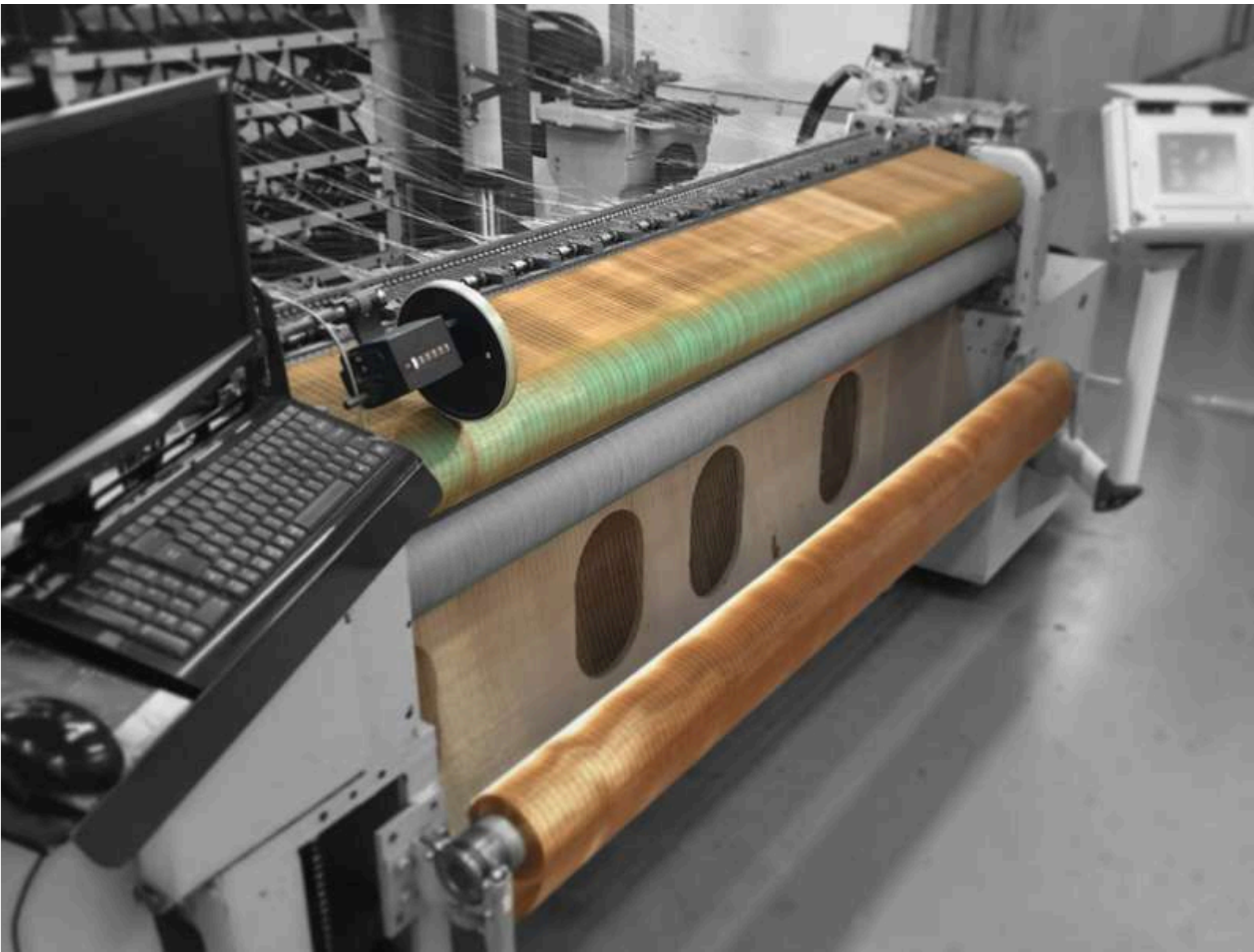

## THE SAME WAY A FIBRE YARN IS WOVEN INTO A TEXTILE FABRIC, BUT VERY DIFFERENT.

It is the only woven fabric in the world to be **angular selective** in its nature.

we take recycled copper wire, form it into a paper thin louvre & weave it into a sustainable KoolShaded fabric

A result of decades of extensive **international research and development**, KoolShade® is a high-performance, woven metal fabric, with its weft constructed of bronze louvres. It can be used in its fabric form or tensioned in a frame, for controlling and diffusing sun, light and air.

The micro-fine louvres are angled to suit a number of applications, whether to ensure optimum light in or redirect light, whilst blocking heat and glare, or to allow ventilation and filtration of air.

10

Product

KOOLSHADE® FABRIC IS WHAT WE WEAVE.

First created in the 1940s SmartLouvre Technology has brought this **solar shading technology** into the 21st century. The original weaving machines have been computerised and a range of fabrics has been developed to further combat solar heat gain.

**K700-17 17°** Weft Angle. Openness factor: **67%**

**Fabric Weight:** 1.10 kg / m2  
**Clear open area:** 80%  
**Fabric composition:** 90% CuZn15 (C230) commercial bronze and 10% CUSi3Mn1 (C655) silicon bronze

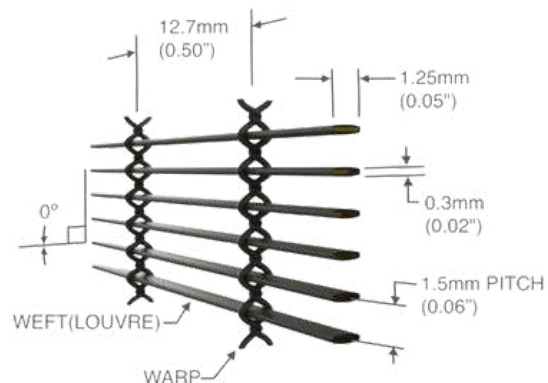
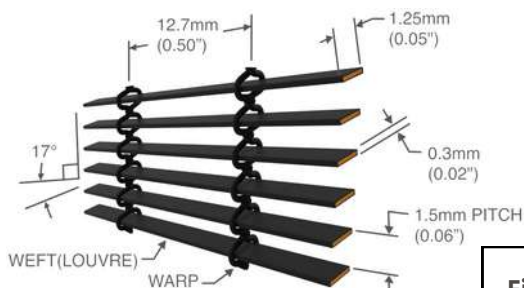

**K700-0 0°** Weft Angle  
Openness factor: **80%**

**Finishes:**  
Polyester powder coat in any RAL colour (with the ability to create designs on the fabric which are directionally visible)

**Fire rating:**  
Class A1/A2-s1,d0 in accordance with BS EN 13501-1:2007+A1:2009

**Resistance to wind:**  
Hurricane proof: 100mph/160kph

Fabric

**K700-17-LSA 17°** Weft Angle. Openness factor: **63%**

**Fabric Weight:** 1.35kg / m2  
**Clear open area:** 80%  
**Fabric composition:** 90% CuZn15 (C230) commercial bronze and 10% CUSi3Mn1 (C655) silicon bronze

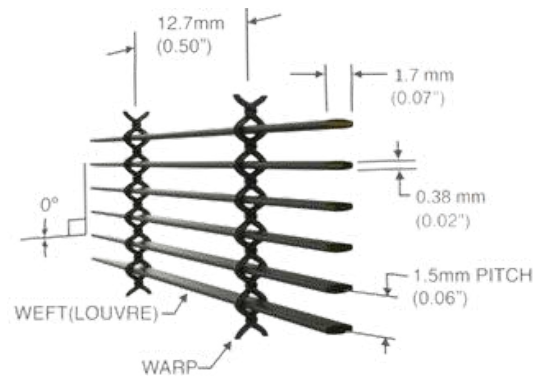
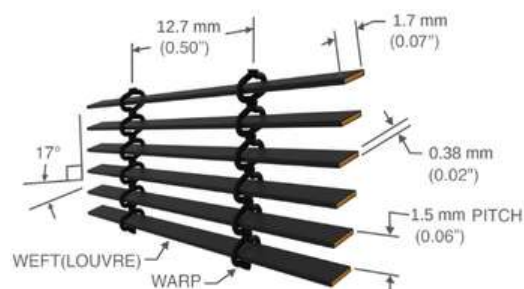

**K700-0-LSA 0°** Weft Angle  
Openness factor: **80%**

**Vision out** →

KoolShade® has achieved top Class 4 classification for Thermal Comfort, Daylight Utilisation and Contact with the Outside, with **100% daylight quality Colour Rendering Index (\*AST)**

Made from over 90% recycled scrap metal & **100% recyclable** KoolShade® has never been more beneficial; to you, your buildings and in the race against climate change.

← **Daylight in**



**IT HELPS CREATE  
PASSIV HAUS HOMES  
THAT PROMOTE WELLBEING**



# 12

Product

**KoolShade®** Solar Screens fix seamlessly to existing windows and mullions to complement the window array.

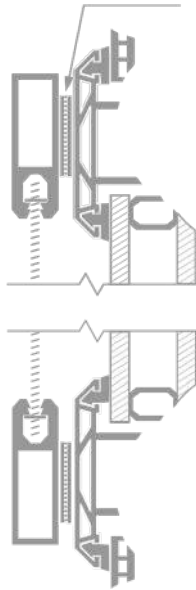
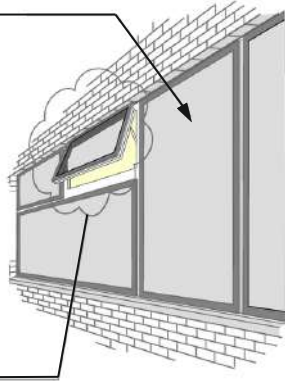

**3M** Dual Lock Fastening system provides great fixing strength while allowing easy access for window maintenance



The Screens fixed to opening lights will not impede on the window's function.

## DIRECT FIX INSTALLATION

Bespoke 316 Stainless Steel Cable Mounting System with fastener components.

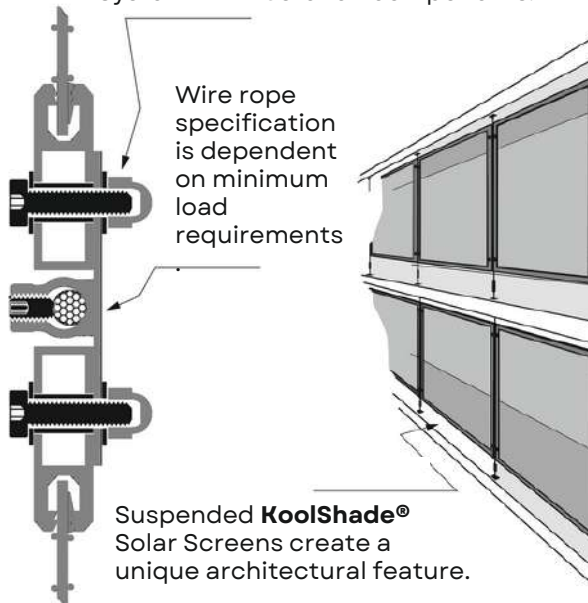

Wire rope specification is dependent on minimum load requirements

Suspended **KoolShade®** Solar Screens create a unique architectural feature.

## CABLE FIX INSTALLATION



All frame extrusions are polyester powder coated. Any commercially available RAL colour can be chosen to meet or exceed ISO 2409 and ISO 9227.

All drawings are for illustrative purposes only and NOT to scale.

# OFFSET HINGE INSTALLATION

DN28/V Drop Nose Latch provides a secure hold with a quick release.

KoolShade® Solar Screens fix seamlessly to existing windows & mullions to complement the original glazing.

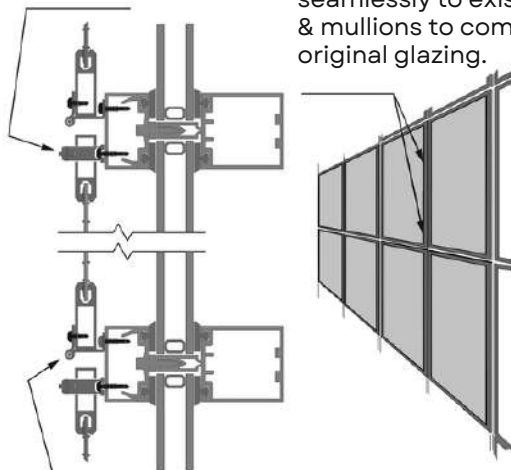

OH76 Offset Hinge Mounting allows for easy access for window maintenance.



# LIFT-IN LIFT-OUT (LiLo) INSTALLATION



Detent ring-pin to lock down the panels.

Alternating overlapped KoolShade® Solar Screens replicate the existing glazing.

Profile:  
DT-34  
Top Track

Profile:  
BT-32  
Bottom Track

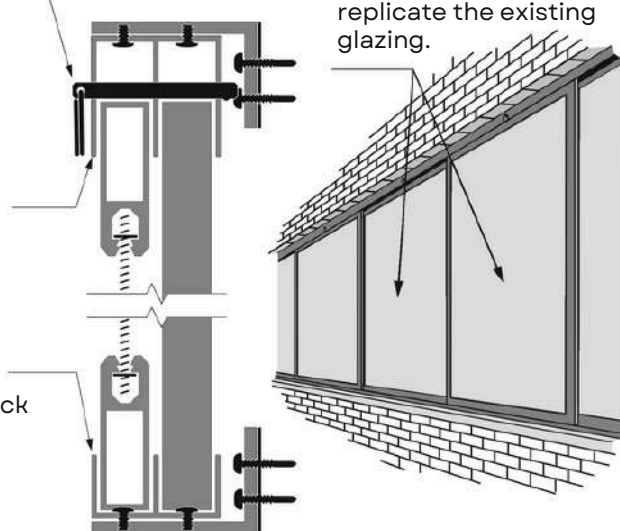

# ROLLER TRACK INSTALLATION

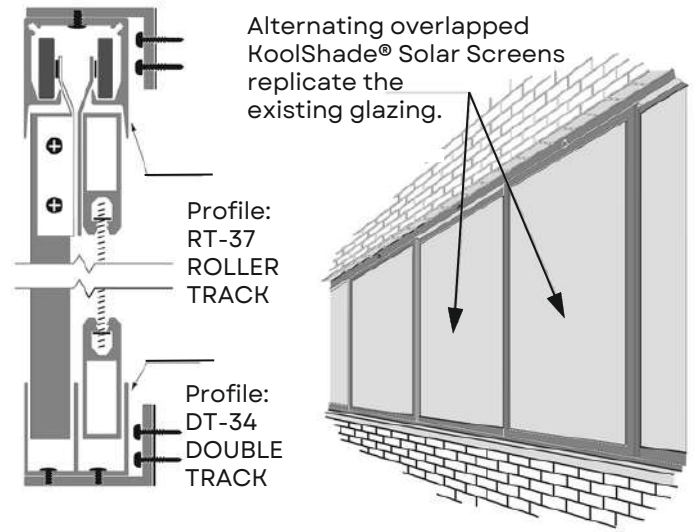

# ROOF LIGHT INSTALLATION



Simple to fit & remove from in or outside



## TabLock

Location tabs fit to existing pre-drilled holes. These slot into the bottom of the frame.

## 3M DualLock

GripLock tabs are fixed top left & right, inside the frame, to hold it in place.

## SLIDING

## GABLE ENDS

## DIRECT TO GLASS



## KOOL-KLIP



Simply position & fit the bottom and top clips to your surface



Locate frame into bottom clips and move the fix-clips to the middle



Push the fix-clips outward and into the top clips in & you hear them snap into place



## KoolShade Solar Shading Screens

## KOOL-KLICK



Simply position & fix the bottom lugs and top clips



Locate lugs into pre-drilled holes on the bottom frame



Push the frame until you hear the Klick!



IT REALLY IS AS EASY AS 1, 2, KLICK!

**Frames are a popular way to use KoolShade**

**16**

Product



Three profile sizes are available to accommodate frame sizes of up to 1,800 x 3,000mm.

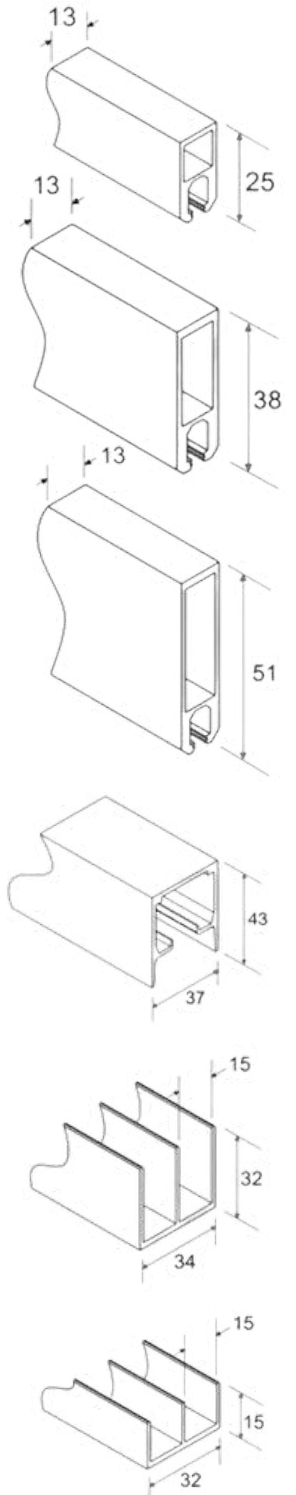

Channel extrusion is fitted to the required area to support the screens.

The channel extrusions can be fitted using a direct fix, bracket and/or VHB Bond fix.

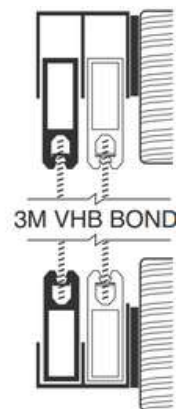
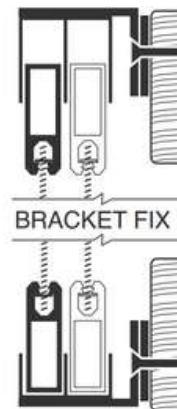
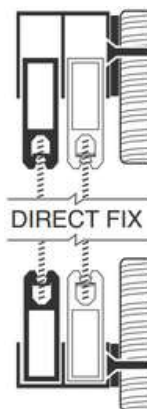

**Easy to remove**  
**No maintenance**  
**Insect Protection**  
**Available in FHA**  
**Available in A1/A2**

Products & Systems	Summary of Systems					
<b>Static Fix</b>	<i>KoolShade static solar screens fix seamlessly to existing windows and mullions to compliment or replicatethe original window array</i>					
Screws - With concealing caps	Fastening through the screen frame makes a strong, semi-permanent fixing		x	x	x	x
3M Dual Lock - Outward opening windows & or direct to glazing	Using 3M Dual Lock provides a semi-permanent fixing that will not penetrate the window frame	x	x	x		
Quick Clips	Quick clips provide a quick, easy way to attach & remove screens for access	x	x	x		x
Screen Clamps	Screen clamps provide a quick & easy way to attach and remove screens for access	x	x	x		x
CP38 & CP51	With the new and improved CP38 & CP51 corner piece, M4 fastening can be utilized to suit a variety of installation methods	x	x	x		x
<b>Roller Track / Traverse</b>	Alternating overlapped Roller Track solar screens replicate the existing glazing					
Face Fix. Top & Bottom tracks with Angle Brackets - Screws, Anchors	Fastening through track brackets to the face of any suitable substrate allows track roller ML screens to be seamlessly integrated into any window array			x		
Face Fix. Top & Bottom tracks with 3M VHB	If a non-penatrative installation is required 3M VHB can be used to fix the roller track directly to most substrates including glass			x		
Reveal Fix. Top & Bottom tracks -3M VHB, Screws and Anchors	When a reveal fix is the best option ML roller top track and bottom track is perfect for the job			x		
Both - Face & Reveal Combined	For more complex installations ML roller track can be installed in a combination of face and reveal fix with ease			x		
<b>Lift In - Lift Out (LiLo)</b>	Alternating overlapped LiLo solar screens replicate the existing glazing					
Face Fix. Top & Bottom tracks with Angle Brackets - Screws, Anchors	Fastening through track brackets to the face of any suitable substrate allows LiLo screens to be seamlessly integrated into any window array	x	x	x	x	x
Face Fix. Top & Bottom tracks with 3M VHB - (Southampton Uni)	If a non-penatrative installation is required 3M VHB can be used to fix the Lift In - Lift Out track directly to most substrates including glass	x	x	x		
Reveal Fix. Top & Bottom tracks -3M, Screws, Anchors	When a reveal fix is the best option LiLo top & bottom track is perfect for the job	x	x	x	x*	x*
Both - Face & Reveal Combined	For more complex installations ML roller track can be installed in a combination of face and reveal fix withease	x	x	x	x	x
<b>Vertical Track / Sash</b>	KoolShade vertical track solar screens fix seamlessly to existing windows and mullions to compliment or replicate the original window array					
Face Fix. DT34 LH/RH Side - Sash window	For sash windows & vertically aligned glazing where ease of access is needed ML Vertical screens are the ideal option. Using specially designed stainless steel leaf springs the screens remain in position wherever you want them			x	x	x
Reveal Fix. DT34 LH/RH Side -Sash window	When a reveal fix is the best option over a shash window ML Vertical Track is perfect for the job. Using specially designed stainless steel leaf springs the screens remain in position wherever you want them			x	x	x
<b>Hinged</b>	KoolShade hinged solar screens fix seamlessly to existing windows and mullions to compliment or replicate the original window array					
Flush - With latch/catch/lock	A discrete hinge installationthat allows for quick, easy access for window cleaning & maintenance		x	x	x	x
Offset - With latch/catch/lock	When a reveal fit makes access to install hinged screens seem impossible our offset hinge option is ideal.		x	x	x	x
Lift off - With latch/catch/lock	Ease of access to the window for cleaning with the ability to remove the ML screens to store or simply stay out of the way during window maintenance	x		x	x	x



- Made from 90+% recycled material
- Maintenance free
- NO plastic or vinyl

- Over 68% saving in air-con costs
- 100% Recyclable
- 60+ year life span

# Sustainability



We meet the needs of the present without compromising the ability of future generations to meet their own needs

KoolShade® is also a passive system that requires zero energy to maintain peak performance

0%

100%

KoolShade® metal fabrics & frames are fully recyclable

The metal fabrics are made from over

**90%+**  
recycled  
scrap copper

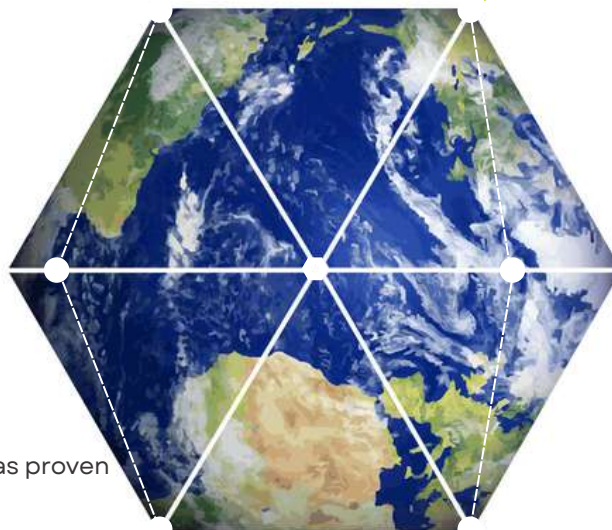

Air conditioning usage can be reduced by over

**68%\***  
when used as  
Solar Shading

KoolShade® has proven longevity with

**60+**  
maintenance free years

**100%** Sustainable



\*Test results and performance are based on LBNL Research undertaken in California, USA. Results may vary depending on your location

## Fire Safe. For People & Building Protection

Fires in high rise buildings are becoming increasingly commonplace and more & more regulations are demanding **EN 13501 A1/A2** etc Reaction to Fire/Fire Resistance for external attachments like sun shading devices.

Koolshade is a multi-function, all-in-one shading, natural ventilation and daylight maximising system and is fully A1/A2 -s1,d0 to EN 13501

KoolShade® also achieves the top Classification for Wildfire and Bush Fire protection to:

- **AS 3959**
- **BAL- FZ** Top Classification: Direct exposure to flames, radiant heat & burning embers
- **BAL -40** Top Classification: Ember attack & burning debris.
- Radiant Heat 29 KW/m<sup>2</sup> & 40KW/m<sup>2</sup>

**A** = Combustibility

**'A1/A2'**: Top Classifications

**'s'** = Smoke & Toxic Gases

**'s1'**: Top Classification

**'d'** = Burning Droplets

**'d0'** = Top Classification

**BAL - FZ** - 49.4 Heat Attenuation

**BAL - 40** Whole window



# 20

Projects

# PROJECT EXAMPLES

Huu-ay-aht First Nations



Monterrey Airport



The Glass House



# Louvlux

Expert Shading Solutions





22

Projects

HAZENDAL  
ANNO 1659

**Hazendal Wine Estate in Stellenbosch is one of South Africa's most famous wine producers and Premium Lifestyle Estates.**

Their beautiful venue 'The Glasshouse', suffered from excessive heat and glare due to the all-glass construction. Temperatures had to be reduced whilst maintaining contact with the beautiful surrounding gardens.

## UNUSABLE FOR 6 MONTHS OF THE YEAR DUE TO SOLAR HEAT GAIN MEANT A SIGNIFICANT LOSS OF EARNINGS

An internal aluminium louvre system inside the glass roof was both ineffective and blocked natural daylight and vision.

**The Glasshouse has to be used for all-year-round;** weddings parties, and business functions, therefore, a solution had to be found.

The Estate's Project Managers, recommended that Koolshade® solar shading would significantly benefit their building with an integrated solution.

Koolshade® K700-17, woven with miniature tiny paper-thin, angled copper louvres was quickly and unobtrusively installed with brackets attached directly to the glass using the 3m VHB tape system.

**Direct-to-glass fixing** is possible because Koolshade® is so light and windproof because its 87% open area provides negligible wind resistance.

## KOOLSHADE® SCREENS WERE FITTED DIRECT-TO-GLASS USING 3M

The client agreed that no other product could have given the same aesthetics and solar heat block together with **natural ventilation, natural light, and perfect vision out.**

## NOW USABLE 24/7 - 365 WITH A HUGE REDUCTION IN AIR-CON COST, GIVING AN IMMEDIATE R.O.I.

We finished the new installation on 24th March 2021 during a **peak solar heat gain period** and immediately, significant reductions in temperature were experienced, such that air conditioning was not even needed at that time.



# 24

PROJECTS



**Monterrey Airport terminal B** was overheating with internal temperatures reaching well over 40° C. This meant an uncomfortable and unpleasant experience for **travellers and staff alike**.

## TERMINAL 'B' WAS OVERHEATING WITH INTERNAL TEMPERATURES REACHING OVER 40° C.

Architecturally beautiful, in its design aesthetic, the General Mariano Escobedo International Airport was lacking in its function due to insufficient climate control in the busiest thoroughfares.

Downtime caused by redesign or installation of additional mechanical methods of cooling was unimaginable and would have proven extremely costly.

So **what could be done about a 40+° C airport?**

The **Angular Selective Nature of Koolshade®** meant that whilst the sun's heat is stopped, 100% pure, full colour rendered (CRI) daylight still floods through for the occupants.

**The first phase** commenced in February 2023. 132 screens were manufactured, quality checked and processed before being shipped directly to site.

On arrival in Mexico, the assembled Kapra team unpacked the shipment and got to work. The glazed arches that allowed light into Terminal B were completely covered in Koolshade® and an immediate drop in internal temperature of over 10° C was measured.

**The second phase**, consisting of 554 screens, commenced in June 2023 and involved the air-side elevation that contained the shops, restaurants and waiting areas of the airport.

Using the  **cable-stayed fix**, the vast area of glazing, that was causing the unmanageable overheating, was cured with Koolshade®.

The installation has become an architectural feature with incredible benefits to the travellers, staff and financial stakeholders of this airport.

## TEMPERATURES REDUCED BY UP TO 26°F (15°C) MAKING THE TERMINAL COOL & COMFORTABLE



# 26

PROJECTS



**Monterrey Airport terminal B** was overheating with internal temperatures reaching well over 40° C. This meant an uncomfortable and unpleasant experience for **travellers and staff alike**.

## **KOOLSHADE® SCREENS WERE IMPLEMENTED TO PREVENT SOLAR GLARE NUISANCE AND ENSURE VISUAL COMFORT WITH THE OUTSIDE.**

However, when they put the design through a software program that tracked the profile and azimuth of the sun's path throughout the year, they discovered otherwise.

The low angled sun in the early morning, late afternoon in the summer, and well always in the late Fall, Winter, and early Spring would cause some discomforting glare to the occupants.

The native band's building committee had made several important requests.

When the designers at the architectural firm of **David Nairne + Associates** located in North Vancouver, first developed a design for this multi-purpose building on the Huu-Ay-Aht First Nations reserve in Bamfield, BC, they assumed that the generous overhang would be sufficient to shade the sun-facing windows.

A reduction in the amount of solar gain was one of the reasons why Koolshade® was specified. Our Koolshade® screens were quickly and easily fitted on the outside of windows thus lowering the amount of direct sunlight whilst still allowing clear views through the large windows.

After the installation of the Koolshade® screens and after several months of sunny and warm weather, it was reported that all the design requirements had been met to the satisfaction of both the architects and the owners.

# **SIGNIFICANT REDUCTIONS OF SOLAR HEAT GAIN & PERMANENT UNOBSTRUCTED VIEWS OF THE PACIFIC OCEAN**

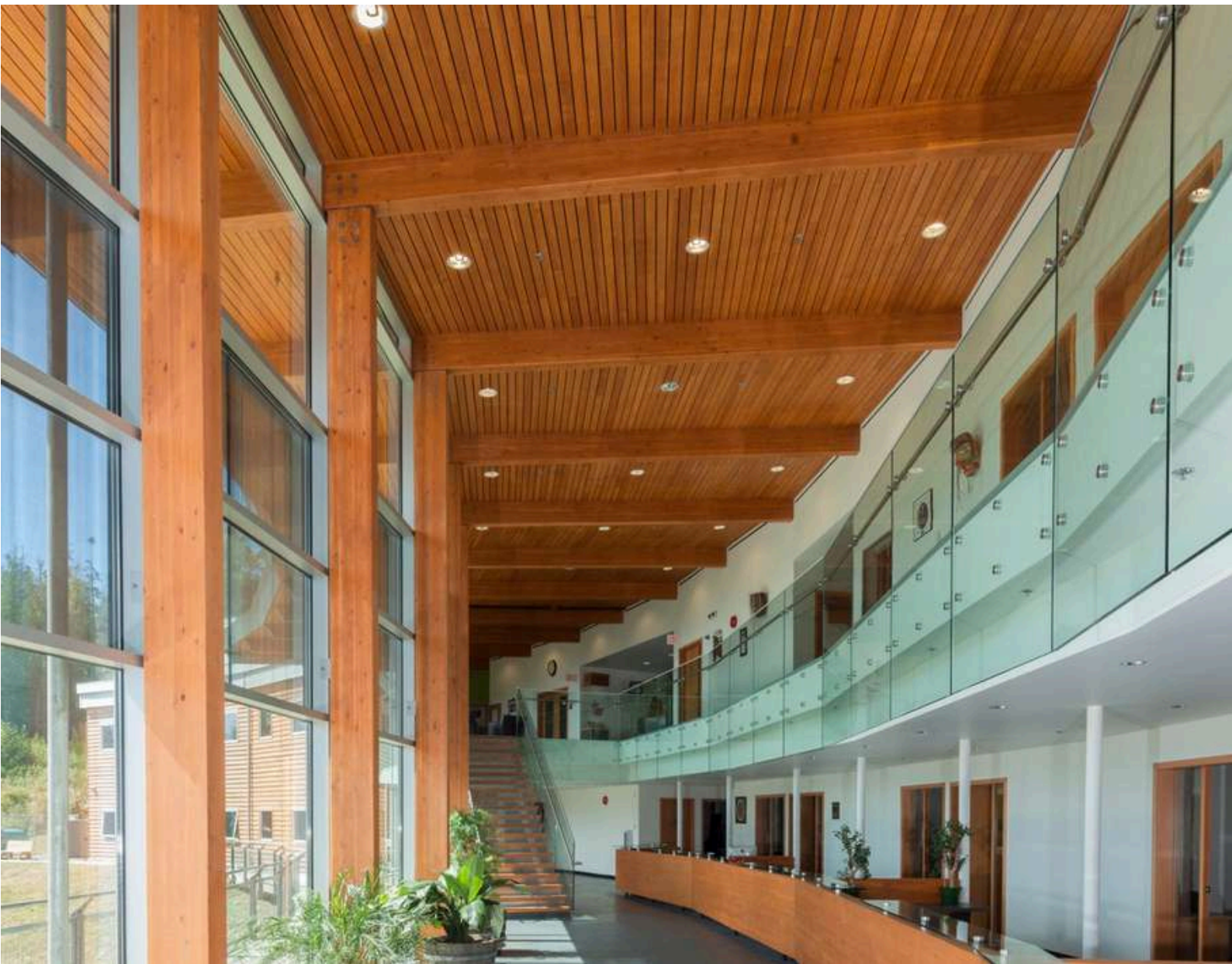

# 28

Finishes

# COLOURS

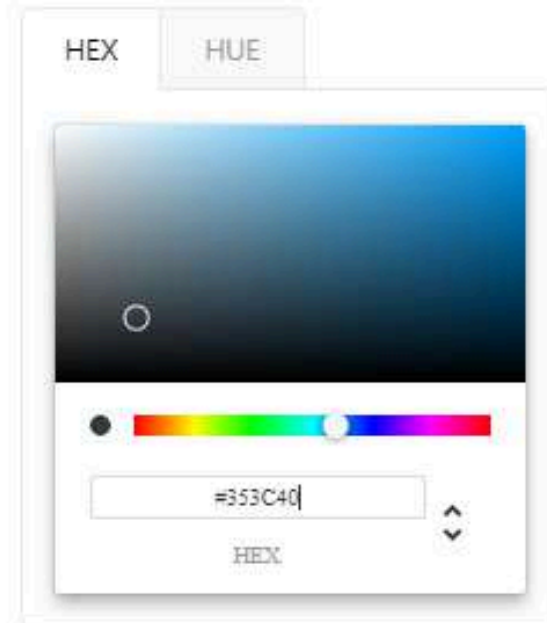

#353c40

≈ Anthracite Grey

## Color-Conversion

HEX #2596be



HSL 202, 9, 23



RGB 53, 60, 64, 1



XYZ 4, 4, 5



CMYK 17, 6, 0, 75



LUV 25, -4, -4



LAB 25, -2, -3



HWB 202, 21, 75



LITERALLY, ANY COLOUR YOU CHOOSE

fabric & fixings  
in any colour  
under the sky



Summary of testing, accreditations, memberships and certification

- 45%** 45% back of room daylight transmittance.  
BRE Daylight and Solar Transmittance of KoolShade.
- 100 mph** 100mph+ winds.  
No damage witnessed at BRE wind tunnel test - certified.
- 92%** 92% Solar radiation rejected.  
Mid-pane Glass D (Best number) , London UK.
- 89%** 89% Solar radiation rejected.  
External Glass D (Best external) , London UK.
- 12%** 12% Solar heat gain co-efficient (g-value).  
Calculation of summertime solar shading performance for KoolShade.
- 12%** 12% Solar transmittance or Ts.  
Calculation of summertime solar shading performance for KoolShade.
- 3%** 3% Solar reflectance or Tr.  
Calculation of summertime solar shading performance for KoolShade.
- 85%** 85% Solar absorption or Ta.  
Calculation of summertime solar shading performance for KoolShade.
- 60+ years** 60+ years service life.  
Ref City County Building - Indianapolis, Indiana.
- 49%** 49.4% fire attenuation.  
Compliant screening for bushfire up to BAL-40 (Australia).
- 80%** 80% Free air flow ventilation  
Proprietary Testing - Physical measurement.
- A1** Fire Rating - Class A1.  
In accordance with BS EN 13501-1:2002
- 68%** 68% Reduction in cooling loads.  
LBNL FlexLab - 48hrs Oct.21-22, 2015.
- 52%** 52% UV Transmittance.  
TAIT: UV transmission regardless of sun angle.
- 100%** 100% Solar shading.  
YELLOTT: Sun angle above 40deg.
- 52%** 51.5% Daylight transmission or Tvis or Tv.  
YELLOTT: Daylight transmission regardless of sun angle.
- 100%** 100% Solar radiation rejected.  
YELLOTT: Sun angle above 40deg.
- NaCl +H2O** Salt Water Testing.  
Akzo Nobel.

Summary of testing, accreditations, memberships and certification

EXTERNAL	Tester/Body	Test Name	Test Summary
	AkzoNobel	AkzoNobel Coating Testing for MicroLouvre™ K700 Metal Fabric Test Summary	
	AkzoNobel	AkzoNobel Fire Propagation and Flame Spread in Powder Coatings	FIRE SAFE & SALT WATER TESTING
	AkzoNobel	AkzoNobel Salt spray test - Original	
	BRE	BRE - Certificate Of Test	
	BRE	BRE - High Speed Wind Integrity Test	
	BRE	BRE - Smartlouvre solar modelling report - Final	WIND RESISTANCE & SHADING PERFORMANCE
	BRE	BRE Light diffusion tests in white KoolShade – Coopers datasheet	
	BRE	BRE MicroLouvre Screens Wind Tunnel Testing BRE	
	CSIRO	CSIRO Raidant Heat & Burning Ember Protection Report	FIRE PROTECTION
	Fraunhofer	Fraunhofer angle-dependent light and solar transmittance measurements report 2	
	Fraunhofer	Fraunhofer Test Report - Black	
	Fraunhofer	Fraunhofer Test Report - With Watermark	
	Fraunhofer	Fraunhofer ANTU EEB3-UA-2106-E02_EPP	ANGLE DEPENDENT LIGHT & SOLAR TRANSMITTANCE
	Fraunhofer	Fraunhofer CLEAR COAT EEB3-HRW-2210-E15_smartlouvre_221011	
Fraunhofer	Fraunhofer Sikkens		
Fraunhofer	Fraunhofer Tasliq		
IFC	IFC MicroLouvre FHA Test Certificate Metal Fabric-1a		
IFC	IFC A1 A2 Test Summary	FIRE SAFE	
IFC	IFC Official Letter		
Interpon	Interpon D - Fire Test Compilation	FIRE SAFE	
ISO	ISO Cert	QUALITY	
LBNL	LBNL ORIGINAL TEST RESULTS lbnl-2001051		
LBNL	LBNL TECHNOLOGY ASSESSMENT OF HIGH PERFORMANCE BUILDING ENVELOPES SUMMARY	COLLING LOAD REDUCTION	
O.Lof	O.LOF Decibel Traffic Sound test . pdf	NOISE REDUCTION	
SIMSCALE	SIMSCALE Smartlouvre MicroLouvre Modelling User Guide v6	FINITE ELEMENT ANALYSIS & THERMAL SIMULATION	
TAIT	TAIT SOLAR OPTICAL PROPERTIES Black		
TAIT	TAIT SOLAR OPTICAL PROPERTIES White docx	HEAT TRANSFER COEFFICIENT	
Yellott	Yellott	ENERGY CONSERVATION	



INTERNAL	Tester/Body	Test Name	Test Summary
	SmartLouvre	KoolShade MicroLouvre light diffusion test	LIGHT DIFFUSION
	SmartLouvre	Heat Comparison chart 2	HEAT GAIN
	SmartLouvre	Heat Gain Heat Lamp Comparison charts	
	SmartLouvre	Peak Cooling in kWh - CDG	COOLING
	SmartLouvre	Pressure Test Greene Fire	FABRIC PRESSURE RESISTANCE
	SmartLouvre	Pressure washing ML on building	WASHING
	SmartLouvre	Static Load Test Paper	FABRIC LOAD
	SmartLouvre	Tensile Load Test Paper	
	SmartLouvre	Tensile Test	TENSILE LOAD
	SmartLouvre	Wind Loading Test Report Summary	
	SmartLouvre	Wind Test - MS angles w smoke	WIND LOAD

RELEVANT REPORTS	Tester/Body	Test Name	Test Summary
	Milano D.O.E	Angular dependency of optical TESI_2004-057	ANGULAR EFFECT
	BRE	BRE - StudyOnEnergyUseByAirConditioningFinalReport	AIR-CON USAGE
	Uni. Of Florence	Transparent Building Envelope Windows UofFlorence_Transparent-Building-Envelope	BUILDING ENVELOPES

CERTIFICATES	Tester/Body	Test Name	Test Summary
	FHA	FHA MicroLouvre FHA Test Certificate Metal Fabric	FIRE
	Interpon	Interpon MicroLouvre Test Certificate Metal Fabric Fraunhofer	FIRE
	LBNL	LBNL MicroLouvre LBNL Test Certificate	PASSIVE SOLAR SHADING
	SmartLouvre Testing	SLT MicroLouvre Test Certificate Screens Wind Load	WIND LOAD

# LouVLux

Expert Shading Solutions